

RUNEQUEST IN GLORANTHA

PERSONAL INFORMATION

Adventurer Name _____ Player Name _____
 Species _____ Age _____ Sex _____ Cults/Religions/Affiliations _____
 Reputation _____
 Ransom _____
 Culture _____

CHARACTERISTICS

STRENGTH _____ Check (STR x 05%) _____
 CONSTITUTION _____ Check (CON x05%) _____
 SIZE _____ _____
 INTELLIGENCE _____ Check (INT x05%) _____
 POWER _____ Luck (POW x05%) _____
 DEXTERITY _____ Check (DEX x05%) _____
 CHARISMA _____ Check (APP x05%) _____

SECONDARY ATTRIBUTES

Damage Bonus _____ Move _____
 Spirit Cmbt. Dmg. _____ DEX SR _____
 Hit Points _____ SIZ SR _____
 Fatigue _____ = SR _____
 Attack Bonus _____
 Parry Bonus _____

SKILLS

AGILITY ()	KNOWLEDGE ()	MANIPULATION ()
Climb (40%) _____ <input type="checkbox"/> Battle (15%) _____ <input type="checkbox"/>	Conceal (05%) _____ <input type="checkbox"/>	Craft _____ (10%) _____ <input type="checkbox"/>
Dodge (DEX x 2%) _____ <input type="checkbox"/> Customs (Own) (25%) _____ <input type="checkbox"/>	Customs Other (00%) _____ <input type="checkbox"/>	Evaluate (05%) _____ <input type="checkbox"/>
Jump (DEX x 3%) _____ <input type="checkbox"/>	Farm (05%) _____ <input type="checkbox"/>	Sleight (05%) _____ <input type="checkbox"/>
Ride _____ (05%) _____ <input type="checkbox"/>	First Aid (10%) _____ <input type="checkbox"/>	PERCEPTION ()
Swim (15%) _____ <input type="checkbox"/>	Herd _____ (05%) _____ <input type="checkbox"/>	Insight (Own Species) (20%) _____ <input type="checkbox"/>
COMMUNICATION ()	Lore _____ <input type="checkbox"/>	Listen (25%) _____ <input type="checkbox"/>
Act (05%) _____ <input type="checkbox"/>	Manage Household (10%) _____ <input type="checkbox"/>	Scan (25%) _____ <input type="checkbox"/>
Art _____ (05%) _____ <input type="checkbox"/>	Read/Write _____ (00%) _____ <input type="checkbox"/>	Search (25%) _____ <input type="checkbox"/>
Bargain (05%) _____ <input type="checkbox"/>	Survival (15%) _____ <input type="checkbox"/>	Track (05%) _____ <input type="checkbox"/>
Charm (15%) _____ <input type="checkbox"/>	MAGIC ()	STEALTH ()
Dance (10%) _____ <input type="checkbox"/>	Meditate (00%) _____ <input type="checkbox"/>	Hide (10%) _____ <input type="checkbox"/>
Disguise (05%) _____ <input type="checkbox"/>	Prepare Corpse (10%) _____ <input type="checkbox"/>	Move Quietly (10%) _____ <input type="checkbox"/>
Fast Talk (05%) _____ <input type="checkbox"/>	Spirit Combat (20%) _____ <input type="checkbox"/>	
Intimidate (15%) _____ <input type="checkbox"/>	Worship _____ (05%) _____ <input type="checkbox"/>	
Intrigue (05%) _____ <input type="checkbox"/>		
Orate (10%) _____ <input type="checkbox"/>		
Sing (10%) _____ <input type="checkbox"/>		
Speak Own Lang. (50%) _____ <input type="checkbox"/>		
Speak Other Lang. (00%) _____ <input type="checkbox"/>		

SPELLS

SPIRIT MAGIK

RUNE MAGIK

PASSIONS & RUNES

PASSIONS

RUNES

Homeland/Clan _____ Residence _____
 Family _____ Social Class _____

HIT POINTS

DEAD (-) 00 01 02

03	04	05	06	07	08	09	10	11	12	13
14	15	16	17	18	19	20	21	22	23	24
25	26	27	28	29	30	31	32	33	34	35
36	37	38	39	40	41	42	43	44	45	46

MAGIK POINTS

UNCONSCIOUS (-) 00

01	02	03	04	05	06	07	08	09	10	11
12	13	14	15	16	17	18	19	20	21	22
23	24	25	26	27	28	29	30	31	32	33
34	35	36	37	38	39	40	41	42	43	44

WEAPONS & SHIELDS

Weapon _____ Damage _____
 SR _____ A% _____ P% _____ AP _____
 Weapon _____ Damage _____
 SR _____ A% _____ P% _____ AP _____
 Weapon _____ Damage _____
 SR _____ A% _____ P% _____ AP _____
 Weapon _____ Damage _____
 SR _____ A% _____ P% _____ AP _____
 Missile _____ Damage _____
 SR _____ A% _____ P% _____ Rng _____
 Missile _____ Damage _____
 SR _____ A% _____ P% _____ Rng _____
 Shield _____ Damage _____
 SR _____ A% _____ P% _____ AP _____
 Shield _____ Damage _____
 SR _____ A% _____ P% _____ AP _____

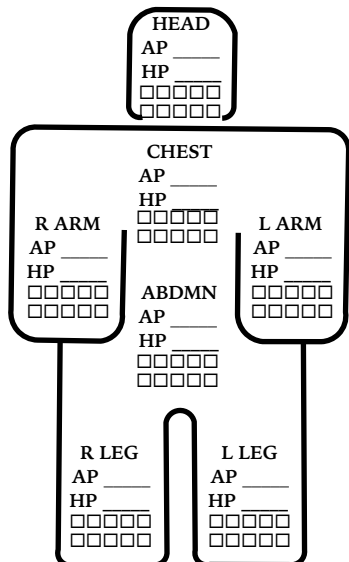

Hit Location Table (humanoid)

Melee	Locations	Missile
01-04	R Leg	01-03
05-08	L Leg	04-06
09-11	Abdomen	07-10
12	Chest	11-15
13-15	R Arm	16-17
16-18	L Arm	18-19
19-20	Head	20

MONEY

CLACKS

LUNARS

WHEELS

OTHER

EQUIPMENT & POSSESSIONS

NOTES

ARMOR TYPE WORN

Head _____ Chest _____

Abdoment _____ Shield _____

Left Arm _____ Right Arm _____

Left Leg _____ Right Leg _____

MAGIK ITEMS

MOUNTS, ELEMENTALS, SPIRITS, FAMILIARS, & FOLLOWERS

Name _____

Species _____ Age _____ Gender _____

Cults _____

Damage _____ Move _____ SR _____

CHARACTERISTICS

STR _____ x5 = Check _____

CON _____ x5 = Check _____

SIZ _____ _____

INT _____ x5 = Check _____

POW _____ x5 = Luck _____

DEX _____ x5 = Check _____

APP _____ x5 = Check _____

Skills _____

Weapon _____ Damage _____

SR _____ A% _____ P% _____ AP _____

Missile _____ Damage _____

SR _____ A% _____ P% _____ AP _____

Shield _____ Damage _____

SR _____ A% _____ P% _____ AP _____

Armor _____

Spells _____

Passions _____

Runes _____

Name _____

Species _____ Age _____ Gender _____

Cults _____

Damage _____ Move _____ SR _____

CHARACTERISTICS

STR _____ x5 = Check _____

CON _____ x5 = Check _____

SIZ _____ _____

INT _____ x5 = Check _____

POW _____ x5 = Luck _____

DEX _____ x5 = Check _____

APP _____ x5 = Check _____

Skills _____

Weapon _____ Damage _____

SR _____ A% _____ P% _____ AP _____

Missile _____ Damage _____

SR _____ A% _____ P% _____ AP _____

Shield _____ Damage _____

SR _____ A% _____ P% _____ AP _____

Armor _____

Spells _____

Passions _____

Runes _____

Name _____

Species _____ Age _____ Gender _____

Cults _____

Damage _____ Move _____ SR _____

CHARACTERISTICS

STR _____ x5 = Check _____

CON _____ x5 = Check _____

SIZ _____ _____

INT _____ x5 = Check _____

POW _____ x5 = Luck _____

DEX _____ x5 = Check _____

APP _____ x5 = Check _____

Skills _____

Weapon _____ Damage _____

SR _____ A% _____ P% _____ AP _____

Missile _____ Damage _____

SR _____ A% _____ P% _____ AP _____

Shield _____ Damage _____

SR _____ A% _____ P% _____ AP _____

Armor _____

Spells _____

Passions _____

Runes _____
